

INSTRUCTION MANUAL

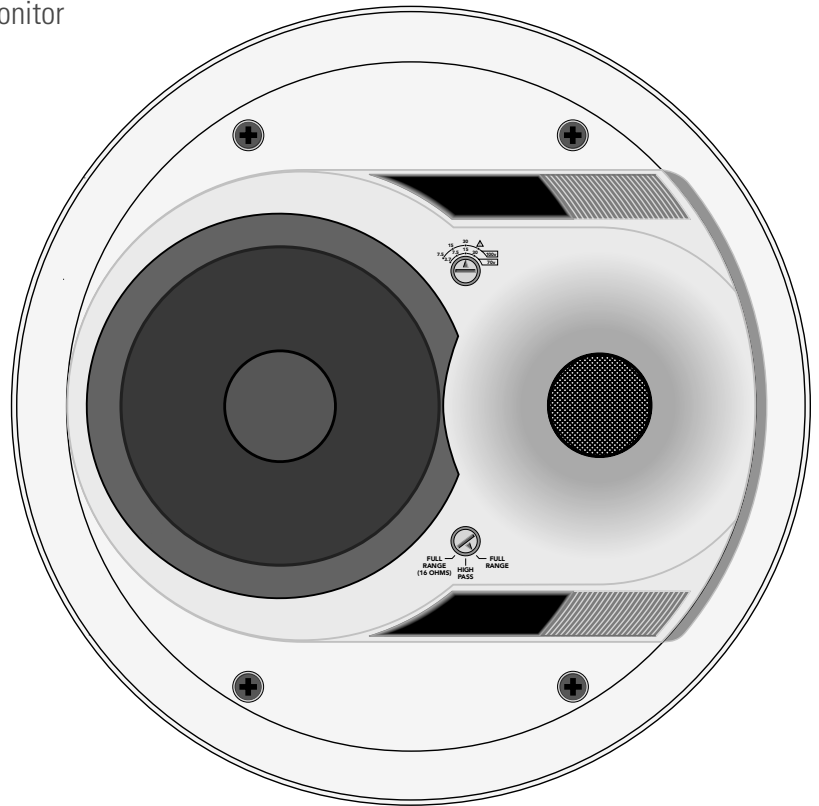

CIS300

2-Way Ceiling Monitor



1. SAFETY INSTRUCTIONS

- 1.1. Read Instructions — Before connecting and using the equipment, please read this Instruction Manual carefully and keep it for future reference.
- 1.2. HEED ALL WARNINGS — Always follow the precautions provided on this EAW Commercial product and in the instruction manual.
- 1.3. Water and Humidity — Do not use this EAW Commercial product near water; for example, in the vicinity of a bath tub or sink, in a damp cellar, near a swimming pool, etc.
- 1.4. Foreign Bodies and Liquids — Be careful not to allow any foreign bodies or liquids to get into this EAW Commercial product.
- 1.5. Servicing — The user should never attempt to make any repairs on this EAW Commercial product unless otherwise indicated in the instruction manual. All repairs should be made by qualified service technicians.
- 1.6. Installation — Do not install this EAW Commercial product in any way that is not provided for in the instruction manual.
- 1.7. Respect the Safety Standards — The entire sound system must be designed in compliance with the current standards and laws regarding electrical systems.
- 1.8. Specifications — When installing and using this EAW Commercial product, keep in mind the technical specifications indicated in the dedicated section of the manual.
- 1.9. Accessories — Install and use this EAW Commercial product only with the accessories specified by the manufacturer or supplied with the product.
- 1.10. Hearing Loss — Exposure to high sound levels can cause permanent hearing loss. The sound pressure level which leads to hearing loss varies considerably from one person to another, and depends on the duration of exposure. The U.S. Government's

Occupational Safety and Health Administration (OSHA) has established the maximum sound pressure levels that can be with stood without causing damage, which are shown in the table below. According to the OSHA regulations, any exposure over the maximum limits indicated in the table can reduce the hearing capacity of a person. To prevent potentially dangerous exposure to high sound pressure levels, anyone subjected to such levels must use suitable protection. When an EAW Commercial product capable of producing high sound levels is being used, it is therefore necessary to wear ear plugs or protective earphones when the limits shown in the table are exceeded.

Consult the specifications provided in the instruction manual to know the maximum sound pressure (SPL) the speaker is capable of producing.

WARNING! This equipment has been designed to be installed by qualified professionals only! There are many factors to be considered when installing professional sound reinforcement systems, including mechanical and electrical considerations, as well as acoustic coverage and performance. LOUD Technologies strongly recommends that this equipment be installed only by a professional sound installer or contractor.

Duration per day (hours)	Sound level (dBA)	Typical example
8	90	Duo in a small club
6	92	
4	95	Subway train
3	97	
2	100	Very loud classical music
1.5	102	
1	105	Locomotive at 50 feet
0.5	110	
0.25 or less	115	Loudest parts at a rock concert

2. TABLE OF CONTENTS

1. SAFETY INSTRUCTIONS	2
2. TABLE OF CONTENTS	2
3. KEY FEATURES	2
4. INTRODUCTION	3
5. PRODUCT DESCRIPTION	3
6. INSTALLING THE CIS300	4
7. SPECIFICATIONS	6
8. SERVICE INFORMATION	8

3. KEY FEATURES

- Proprietary waveguide design to improve hi-frequency dispersion
- Ported design for extended low-frequency response
- 1" soft-dome tweeter with neodymium magnetic motor structure
- 4" low-frequency woofer
- Built-in 70/100V transformer with multiple taps
- Transformer bypass for low-impedance operation (16 ohms)
- True 2-way crossover
- Built-in switchable high-pass filter
- Complete assembly for quick installation
- UL/cUL/CE listed

4. INTRODUCTION

The CIS300 is a complete two-way bass-reflex flush-mount loudspeaker assembly designed for ease of installation, extremely wide coverage, and high-fidelity full-range sound reinforcement.

The CIS300 is ideal for use in business music systems and foreground/background music applications.

Installing the CIS300 is simple. The one-piece assembly includes the backcan, mounting tabs (clamps), front baffle rim, high- and low-frequency drivers, and our proprietary two-way waveguide based on the award-winning Mackie HR824 studio monitors. Support rails are supplied that attach to the C-ring (included) and distribute the speaker's weight to the ceiling tile T-channels. A template is also included for marking the correct cutout size.

The Phoenix-style connector on the back of the assembly provides input and loop-through connections for 70V/100V distribution systems, or low-impedance operation. An easily accessible rotary switch on the front panel selects the appropriate tap (from 3.7 watts to 30 watts). A second switch allows you to select among full-range operation, high-pass

(when used with a subwoofer), and full-range low-impedance operation (16 ohms).

A plastic paint shield is provided that protects the transducers so the front baffle rim and grille can be painted to match the surrounding décor.

5. PRODUCT DESCRIPTION

1. Grille
2. C-Ring
3. Support Rails
4. Mounting Tabs
5. Attachment Screws
6. Backcan
7. Terminal Cover Plate
8. Connector
9. Strain Relief
10. Seismic Safety Tab
11. Waveguide
12. Tap Selector Switch
13. Full-range/High-Pass Selector Switch

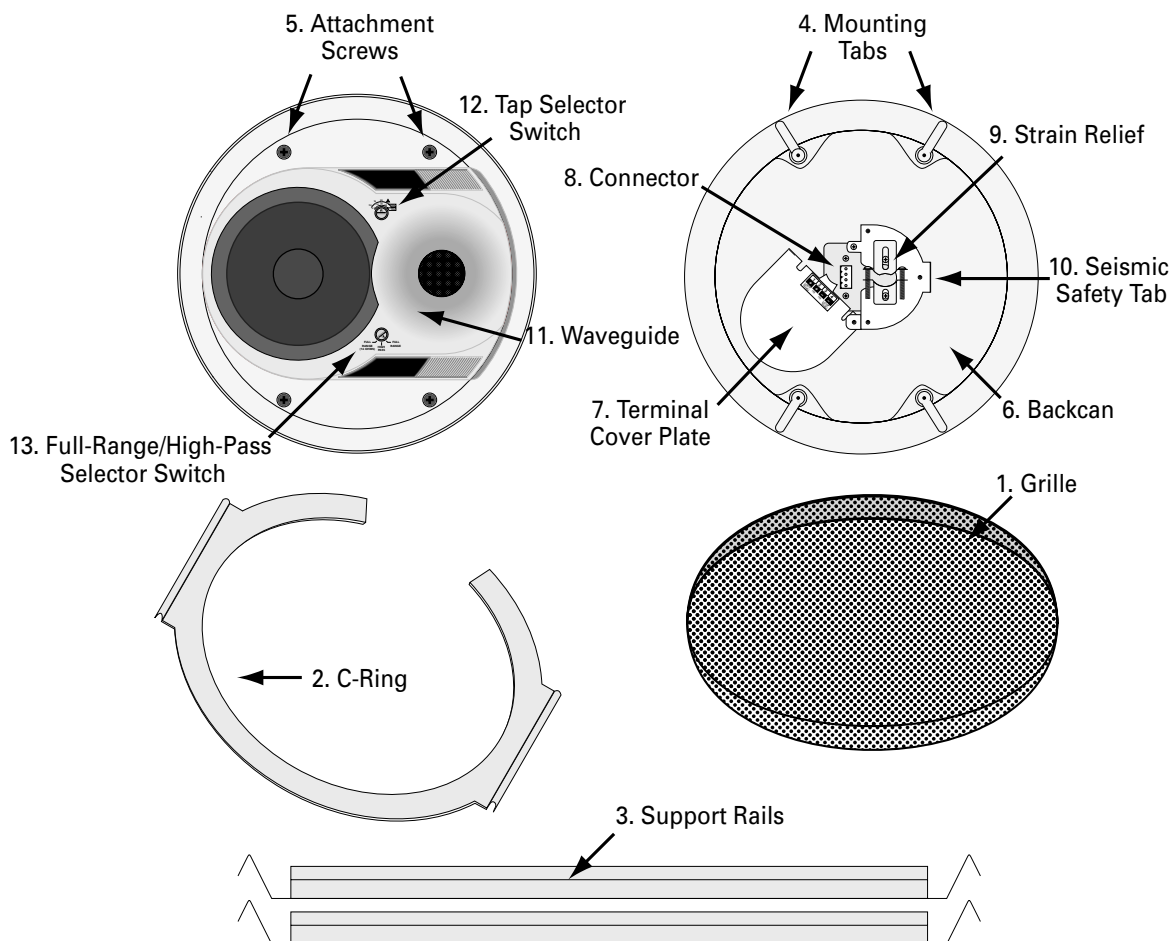

6. INSTALLING THE CIS300

The CIS300 can be installed into suspended or drywall-based ceilings. The speaker is secured in place with the four rotating mounting tabs. The support rails are used with suspended ceilings (standard 24" spacing) to transfer the weight of the speaker to the T-channel runners.

PLACEMENT

There are two considerations when deciding where to place the CIS300 speakers.

Location: When installing the speaker in a suspended ceiling with conventional ceiling tiles, the location of the speaker is determined in part by the support grid of the suspended ceiling system.

When installing the speaker in a drywall ceiling, the location of the speaker is determined in part by the location of the ceiling joists.

Coverage: It is important to locate the speakers in such a way that the sound is evenly distributed over the entire area. Keep in mind that the sound has farther to travel on the outside edge of the coverage area for each individual speaker than directly below the speaker, resulting in a decrease in SPL at the outer edges of the listening plane. The CIS300 is -6 dB at a horizontal off-axis angle of 70° from 1 kHz to 6 kHz (140° coverage).

The speaker placement should be designed such that the edges of the coverage pattern for each speaker are at least touching. The more overlap that is provided (higher density coverage), the more SPL the system is capable of providing and the less variation in level as you move around the area. The downside of higher density coverage, of course, is that more speakers are required for a given area.

INSTALLATION

Note: Observe all local and national codes when installing the CIS300.

1. Cut the hole for the speaker using the supplied cutout template. If using a circular cutter, set the diameter to 7.8 inches (199 mm).

2. Insert the C-ring (2) through the hole so the hanging brackets on the C-ring point up. If installing in a suspended ceiling, align the support rails (3) on either side of the hole and hook them onto the T-channel runners in the suspended ceiling support grid. Then slide the C-ring brackets over the support rails as shown in the illustration below.

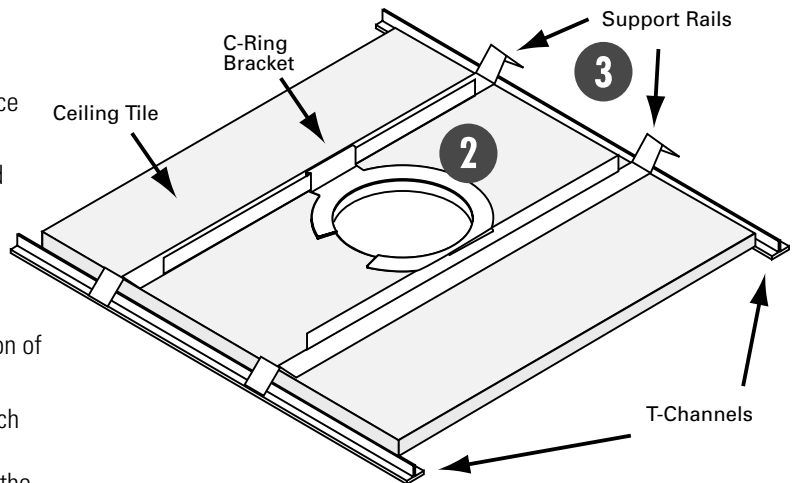

3. You can install the CIS300 speakers using either conduit or plenum-approved jacketed cable.

A. Installation with Plenum-Approved Jacketed Cable or Flexible Conduit

Note: If you can access the back of the CIS300 once it is mounted, you may prefer to do steps A3 and A4 before doing steps A1 and A2.

- A1. Attach the speaker cable to the supplied Phoenix-type connector (8). This is a 4-position connector, with two "+" and two "-" terminals. Connect the speaker cable to the "+" and "-" terminals labeled IN. If connecting another speaker in a distributed system (in parallel), connect the speaker cable running to the next speaker to the "+" and "-" terminals labeled LOOP THRU.

- A2. Open the terminal cover plate (7) on the back of the CIS300. Route the speaker cable through the strain relief bracket (9), and connect the speaker connector (8) to the

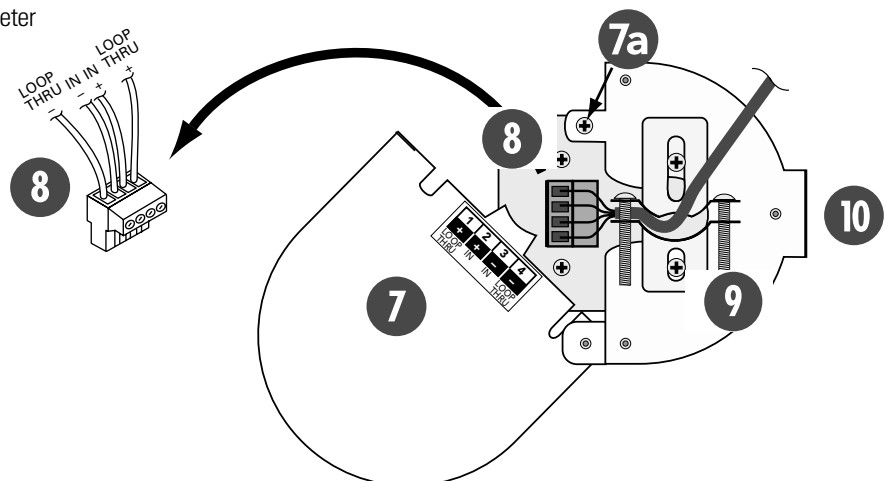

4-pin terminal. Tighten the strain relief screws to secure the speaker cable or flexible conduit. Close the terminal cover plate (7) and tighten the locking screw (7a) firmly.

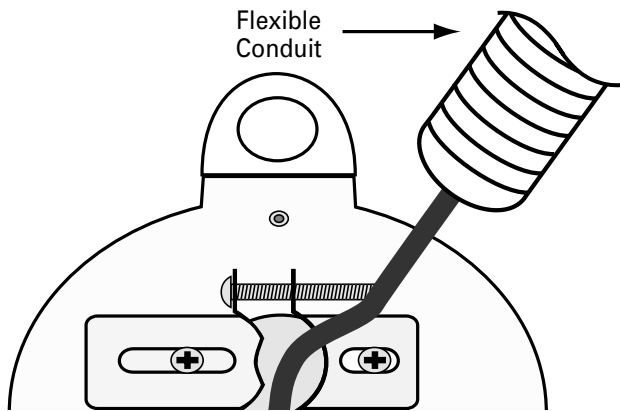

A3. Insert the speaker into the hole all the way, so the front baffle rim is flush against the ceiling.

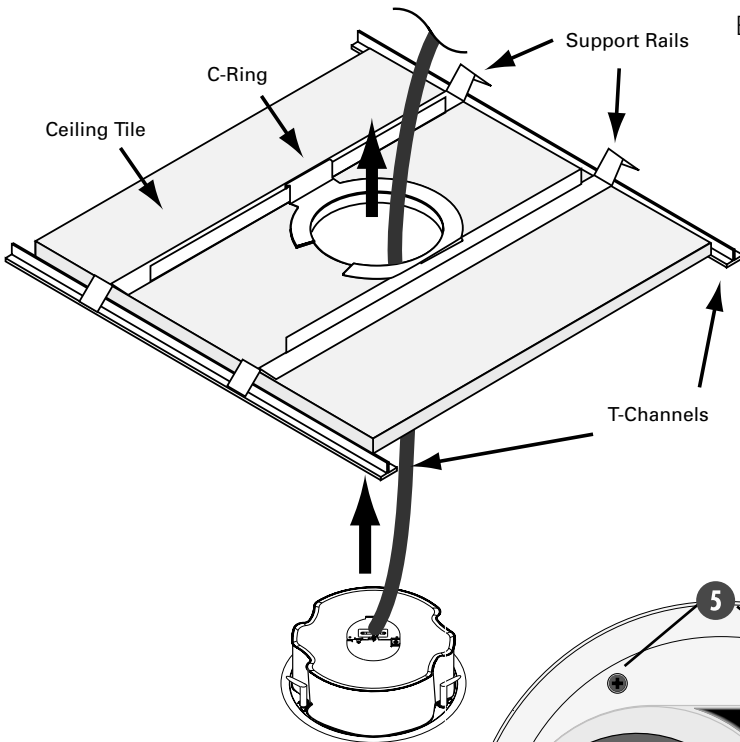

A4. Turn the four attachment screws (5) clockwise until tight to secure the mounting tabs over the C-ring. **DO NOT OVERTIGHTEN.**

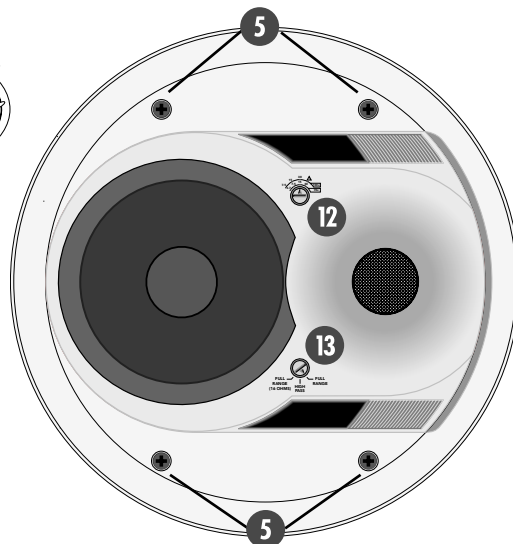

B. Installation to Conduit

B1. Remove the two screws holding the strain relief (9) onto the rear cover and remove the strain relief assembly.

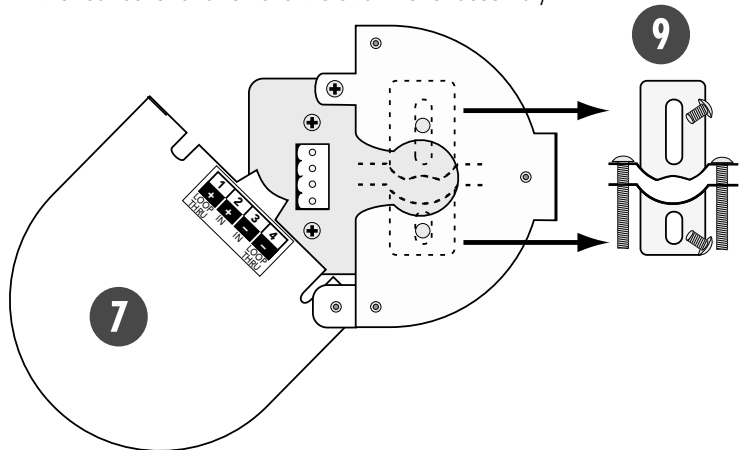

B2. Open the terminal cover plate (7) on the back of the CIS300. Use a threaded conduit set-screw coupler (not supplied: For 1/2" conduit, use Thomas&Betts Steel City model TC221-SC or UL listed equivalent¹) and insert into the opening exposed by removing the strain relief assembly.

B3. Fasten the coupler to the cover using the nut supplied with the coupler.

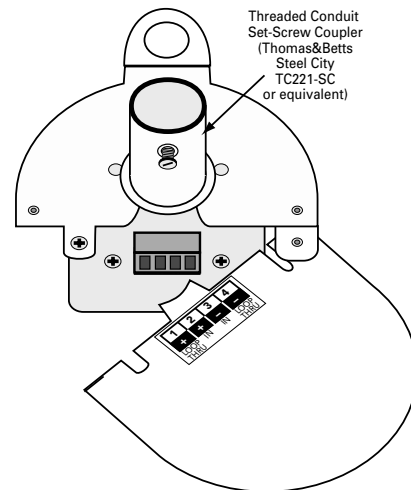

B4. Insert the speaker into the hole all the way, so the front baffle rim is flush against the ceiling.

B5. Turn the four attachment screws (5) clockwise until tight to secure the mounting tabs over the C-ring. **DO NOT OVERTIGHTEN.**

¹ This method can be used with 1/2" flexible conduit by substituting a Thomas&Betts Steel City model XC241 flexible conduit fitting (or UL listed equivalent).

B6. Pull the speaker cable through the conduit coupler and attach to the supplied Phoenix-type connector (8). This is a 4-position connector, with two “+” and two “-” terminals. Connect the speaker cable to the “+” and “-” terminals labeled **IN**. If connecting another speaker in a distributed system (in parallel), connect the speaker cable running to the next speaker to the “+” and “-” terminals labeled **LOOP THRU**.

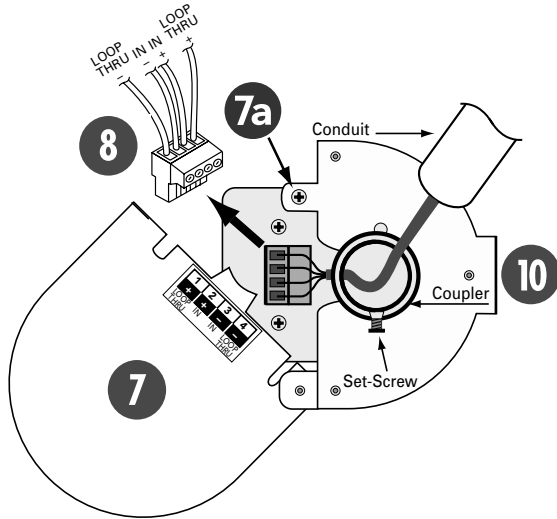

B7. Close the terminal cover plate (7) and tighten the locking screw (7a) firmly.

B8. Insert the conduit into the coupler and fasten with the set-screw.

Note: A seismic safety tab (10) is provided to secure the loudspeaker to the building structure with wire cabling for additional support where required by local construction codes. We recommend using this secondary support for additional safety.

4. Set the Tap Selector Switch (12). Make sure all the taps in the system add up to less than the rated power of the amplifier driving them. As a general rule, you should provide at least 10% headroom to account for insertion losses (i.e., wiring resistance, etc.). For example, if you have four speakers tapped at 15 watts each, the amplifier should be rated at least 66 watts.



5. Set the Full-Range/High-Pass Selector Switch (13). For normal operation, set the switch to the **FULL RANGE** position. If a subwoofer is being used in the system to reinforce the very-low frequencies, use the **HIGH PASS** position to roll off the frequencies below 150 Hz. This provides the added benefit of making more power available for the crucial mid and high frequencies.

If the speaker is being used in a low-impedance system, use the **FULL RANGE (16 OHM)** position. This bypasses the tapped transformer.

6. Install the grille (1) by pressing it into place until the front of the grille is flush with the front baffle rim. It is important that the grille be securely seated to avoid having it vibrate loose.

7. SPECIFICATIONS

System Acoustic

Frequency Range:	90 Hz–22 kHz (–10 dB)
Frequency Response:	110 Hz–20 kHz (–3 dB)
Sensitivity:	90 dB, 1W @ 1m
Crossover Point:	2200 Hz
Power Handling:	30 watts long term
Maximum SPL:	102 dB @ 1m
Transformer Taps	
70V:	3.7 W, 7.5 W, 15 W, 30 W
100V:	7.5 W, 15 W, 30 W
Operation in High-Pass Mode	
Frequency Response:	150 Hz–20 kHz
Operation in Low-Impedance Mode	
Frequency Response:	110 Hz–20 kHz
Control Features	
Front-mounted Rotary Switch:	Full Range (70/100 Volt Systems) High Pass (70/100 Volt Systems) Full Range (16Ω) (Low-impedance Systems)
Front-mounted Rotary Switch:	Secondary Tap Positions

Transducers:

Low Frequency	
Number of Drivers:	1
Woofers Size:	4" (102 mm)
Diaphragm Material:	Polypropylene
Magnet Type:	Ferrite
High Frequency:	
Diaphragm Size:	1" (25 mm)
Diaphragm Material:	Damped Cloth
Magnet Type:	Neodymium
Waveguide Design	
Horizontal Coverage:	140° 1 kHz to 6 kHz averaged
Vertical Coverage:	124° 1 kHz to 6 kHz averaged
Type:	Exponential
Mouth Size:	2.75" x 2.75" (70 mm x 70 mm)
Throat Size:	1.0" (25 mm)

Physical

Construction Features

Basic Design:	2-way, front loaded
Bezel Material:	UL94V-0 rated material
Rear Enclosure Material:	Steel
Grille:	Perforated metal with weather-resistant coating

Safety Features

Rear-hanging Ring:	Safety loop located at rear of enclosure for attachment of load bearing safety strap
--------------------	--

Safety Agency Rating

UL1480:	General Signaling Fire Standard
UL2043:	Fire Test for Heat and Visible Smoke Release for Discrete Products and Their Accessories Installed in Air-handling Spaces

Inputs/Outputs:

Removable locking connector with screw-down terminals
2 input terminals and 2 loop-thru terminals.

Dimensions

Diameter x Height: 8.7 in/221 mm x 5.7 in/144 mm
Front of Ceiling Tile to Back of Back Can:

4.6 in/116 mm

Cutout Size: 7.8 in/199 mm

Net Weight: 6.2 lb/2.8 kg

Included Accessories:

Grille, Support Rails, C-Ring, Removable Locking Connector, Cut-out Template, Paint Shield

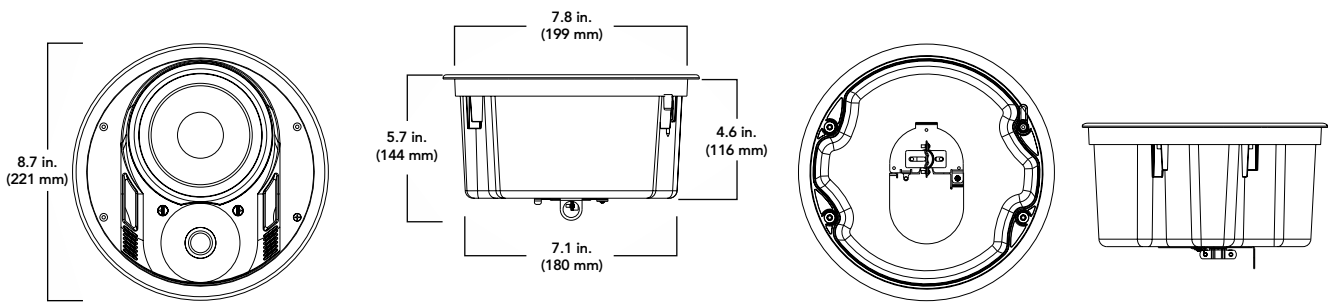

CIS300 Frequency Response vs. Impedance

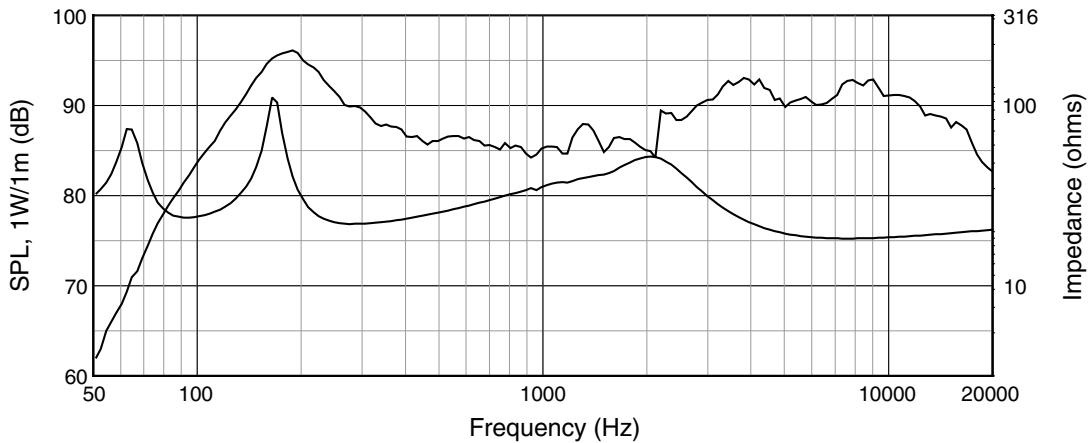

CIS300 Beamwidth vs. Frequency

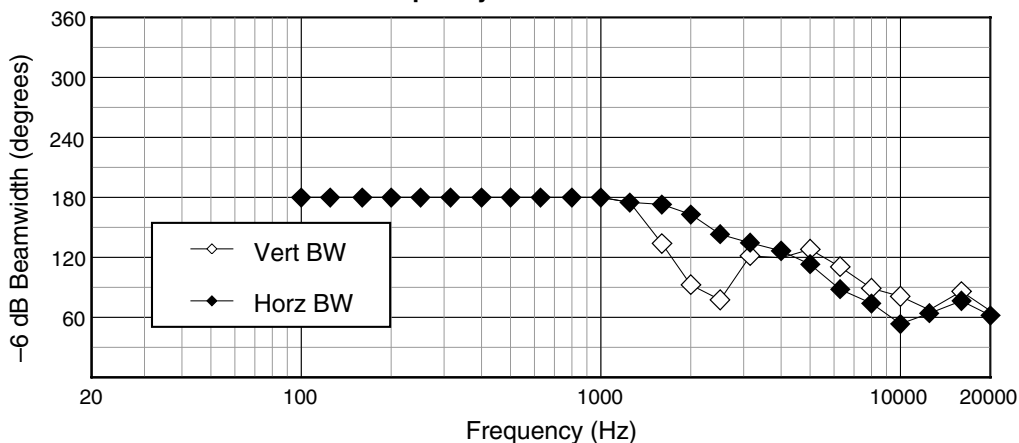

DISCLAIMER

LOUD Technologies Inc. continually engages in research related to product improvement, new materials, and production methods. Design refinements are introduced into existing products without notice as a routine expression of that philosophy. For this reason, any current EAW Commercial product may differ in some respect from its published description, but will always equal or exceed the original design specifications unless otherwise stated.

“EAW Commercial” is a trademark of LOUD Technologies Inc.

All other brand names mentioned are trademarks or registered trademarks of their respective holders, and are hereby acknowledged.

8. SERVICE INFORMATION

In the event that your CIS300 should require servicing, please follow these instructions:

1. Call EAW Commercial Tech Support at 1-888-337-7404, 7 am to 5 pm PST (Monday-Friday), to verify the problem and obtain a Return Authorization (RA) Number. Be sure to have the serial number of the unit when you call. You must have a Return Authorization Number in order to obtain warranty service at the factory or at an authorized service center. You can also email EAW Commercial Tech Support at: support@eawcommercial.com
2. Pack the unit in its original packaging. **THIS IS VERY IMPORTANT.** LOUD Technologies is not responsible for any damage that occurs during shipping due to non-conventional packaging. Original packaging helps to minimize the possibility of shipping damage.
3. Include a legible note stating your name, (no P.O. boxes), daytime phone number, Return Authorization Number, and a detailed description of the problem, including how we can duplicate it.
4. Write the Return Authorization Number in **BIG BOLD PRINT** on the top of the box.
5. Tech Support will tell you where to ship the unit when you call for an RA Number. We suggest insurance for all forms of cartage.



EAW Commercial | One Main Street | Whitinsville, MA 01588 USA

TEL toll free within US/Canada 888.337.7404 | TEL outside US 425.892.6503 | FAX 425.485.1152

www.eawcommercial.com

© 2004 LOUD Technologies Inc. All Rights Reserved. EAW Commercial is a registered trademark of LOUD Technologies Inc.