



# VR61 VR62

Passive Full-Range Loudspeakers



INSTRUCTION MANUAL

# 1. SAFETY INSTRUCTIONS

1. Read these instructions.
2. Keep these instructions.
3. Heed all warnings.
4. Follow all instructions.
5. Do not use this apparatus near water.
6. Clean only with a dry cloth.
7. Do not block any ventilation openings. Install in accordance with the manufacturer's instructions.
8. Do not install near any heat sources such as radiators, heat registers, stoves, or other apparatus (including amplifiers) that produce heat.
9. Only use attachments/accessories specified by the manufacturer.
10. Refer all servicing to qualified service personnel. Servicing is required when the apparatus has been damaged in any way, such as liquid has been spilled or objects have fallen into the apparatus, the apparatus has been exposed to rain or moisture, does not operate normally, or has been dropped.
11. The entire sound system must be designed in compliance with the current standards and laws regarding electrical systems.
12. When installing and using this apparatus, keep in mind the technical specifications indicated in the dedicated section of the manual.
13. Exposure to high sound levels can cause permanent hearing loss. The sound pressure level which leads to hearing loss varies considerably from one person to another, and depends on the duration of exposure. The U.S. Government's Occupational Safety and Health Administration (OSHA) has established the maximum sound pressure levels that can be with stood without causing damage, which are shown in the table below. According to the OSHA regulations, any exposure over the maximum limits indicated in the table can reduce the hearing capacity of a person. To prevent potentially dangerous exposure to high sound pressure levels, anyone subjected to such levels must use suitable protection. When an EAW Commercial product capable of producing high sound levels is being used, it is therefore necessary to wear ear plugs or protective earphones when the limits shown in the table are exceeded. Consult the specifications provided in the instruction manual to know the maximum sound pressure (SPL) the loudspeaker is capable of producing.



*The exclamation point within an equilateral triangle is intended to alert the user of the presence of important operating and maintenance (servicing) instructions in the literature accompanying the apparatus.*



**WARNING!** *This equipment has been designed to be installed by qualified professionals only! There are many factors to be considered when installing professional sound reinforcement systems, including mechanical and electrical considerations, as well as acoustic coverage and performance. EAW Commercial strongly recommends that this equipment be installed only by a professional sound installer or contractor.*

Duration per day (hours)	Sound level (dBA)	Typical example
8	90	Duo in a small club
6	92	
4	95	Subway train
3	97	
2	100	Very loud classical music
1.5	102	
1	105	Locomotive at 50 feet
0.5	110	
0.25 or less	115	Loudest parts at a rock concert

Part No. 0012103 Rev.A 09/2004

© 2004 LOUD Technologies Inc. All Rights Reserved.

14. Rigging Precautions: When mounting or suspending EAW Commercial loudspeaker enclosures, it is essential that load ratings, rigging techniques, and special safety considerations be appropriate for the installation. Use only the mounting/rigging points on the loudspeaker enclosure intended for this purpose. The user must determine the load requirements, dynamic loading, and any other contributing factors affecting the loudspeaker installation. The user must determine the proper design factor for specific applications and the required load rating of the connection to structure. Comply with all applicable federal, state, and local regulations.

EAW Commercial strongly recommends the following rigging system practices:

- Documentation: Thoroughly document the mounting/rigging design with detailed drawings and parts lists.
- Analysis: Have a licensed structural engineer or other qualified professional review and approve the mounting/rigging design before its implementation.
- Installation: Use personnel experienced and qualified for mounting/rigging loudspeakers in accordance with and in compliance with all federal, state and local regulations.



**DANGER:** Loudspeakers should be mounted or suspended only by persons with knowledge of the proper hardware and rigging techniques. When stacking or pole-mounting loudspeakers, be sure that they are stabilized and secured from falling over or being accidentally pushed over. Failure to follow these precautions may result in damage to the equipment, personal injury, or death.

## TABLE OF CONTENTS

<b>1. SAFETY INSTRUCTIONS</b> .....	<b>2</b>
<b>2. INTRODUCTION</b> .....	<b>4</b>
<b>3. INSTALLATION</b> .....	<b>5</b>
<b>4. CONNECTIONS</b> .....	<b>8</b>
<b>5. OPERATION</b> .....	<b>10</b>
<b>6. SPECIFICATIONS</b> .....	<b>11</b>
<b>Dimensions</b> .....	<b>11</b>
<b>Performance Graphs</b> .....	<b>12</b>
<b>7. TROUBLESHOOTING</b> .....	<b>13</b>
<b>8. SERVICE and MAINTENANCE</b> .....	<b>14</b>
<b>9. WARRANTY</b> .....	<b>15</b>

## 2. INTRODUCTION

Congratulations on the purchase of your new EAW Commercial loudspeaker. You now own one of the finest professional audio products available – the result of exceptional engineering and meticulous craftsmanship. Please read these instructions to get the maximum performance from your new loudspeaker.

Each EAW Commercial loudspeaker is intended for professional use. The construction, components, and hardware have been designed to provide robust, reliable performance for its intended application. Please ensure that you fully understand its proper installation and operation before use.

This manual describes the VR61 and VR62 full-range loudspeakers. These offer an attractive design and good acoustic features for quality speech and music reproduction. The extended-range drivers guarantee high efficiency, and a wide angle of coverage over the entire range reproduced.

The VR61 and VR62 provide exceptional fidelity for background and foreground music applications. Their speech projection capabilities also make them highly effective as fill or delay loudspeakers in larger audio systems. The rotatable HF horn allows the enclosure to be mounted either vertically or horizontally with the beamwidth oriented as required. The rugged birch enclosure is available in both black and white finishes. The powder-coated steel grille is foam-backed, providing physical protection for the drivers as well as hiding them from view.

### Features:

- Ultra-compact 2-way loudspeaker
- VR61 has one 6-inch woofer
- VR62 has two 6-inch woofers
- 1-inch exit compression driver, with protection circuit
- Rotatable high-frequency horn with 60 x 90 degree beamwidth
- Passive crossover for economical, single-amplifier operation
- Optional 70 V / 100 V multi-tap transformer
- Includes mounting bracket
- Five-year warranty

### Applications include:

- Under Balcony Fill
- Stage Lip Fill
- Multimedia Systems
- Theaters
- Distributed Systems
- Houses of Worship
- Theme Parks
- Retail Spaces

# 3. INSTALLATION

## Unpacking and Inspection

Visually inspect the outside of the shipping carton and check for any damage. After unpacking, if you find concealed damage to the loudspeaker, save the packing materials for the carrier's inspection, notify the carrier immediately, and file a shipping damage claim. Although EAW Commercial will help in any way possible, it is always the responsibility of the receiving party to file any shipping damage claim. The carrier will help prepare and file this claim.

## Mounting Precautions

The mounting bracket provided can be used for wall mounting the loudspeaker.



**WARNING:** Installation should only be done by an experienced technician. Improper installation may result in damage to the equipment, injury or death. Make sure that the loudspeaker is installed in a stable and secure way in order to avoid any conditions that may be dangerous for persons or structures:

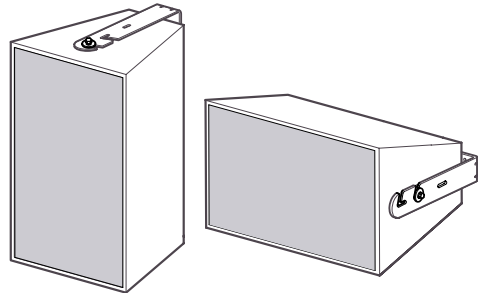

- Check to make sure that the support surface (e.g., wall, etc.) has the necessary mechanical characteristics to support the weight of the loudspeaker without the danger of it falling.
- Always use support elements suitable for the material of the wall that will support the loudspeaker (e.g., screw anchors for bricks, screw anchors for cement, etc.). Due to various construction methods and materials used today, the hardware for securing the bracket to the mounting surface is not supplied. Consult a building professional for the proper mounting hardware before mounting the bracket.
- Before suspending the loudspeaker, carefully check all the components to be used to make sure there is no damage, deformation, corrosion and/or missing or damaged parts that could reduce the safety of the installation.
- Consult a professional rigger or structural engineer prior to suspending loudspeakers from a structure not intended for that use. Always know the working load limit of the structure supporting the loudspeaker. Always make sure that the rigging hardware minimum rating is at least five times the actual load.
- Avoid installing the loudspeaker in places exposed to harsh weather conditions.

# Mounting Instructions

1. Remove the screw from each end of the enclosure as shown below.
2. Align the bracket slots with the mounting holes on each end of the enclosure. Make sure the four openings in the bracket arms face upward.
3. Onto each of the two supplied hex-head screws, place a lock washer, and a flat washer. Thread them at least three complete turns into both of the enclosure's side mounting holes, and tighten them securely.
4. The bracket /enclosure assembly may be mounted vertically or horizontally.
5. The enclosure may be adjusted to any angle by loosening the 2 hex-head screws, turning the enclosure to the desired angle, and then re-tightening the screws.

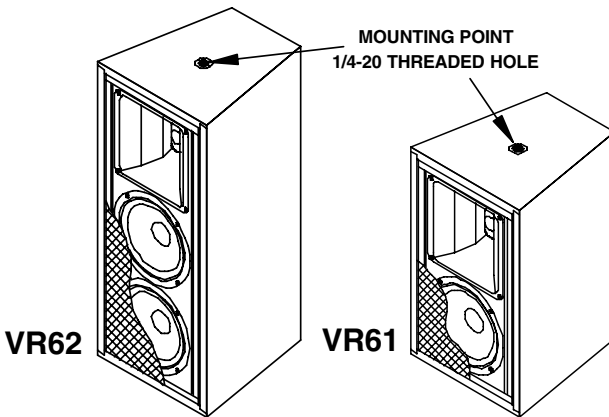
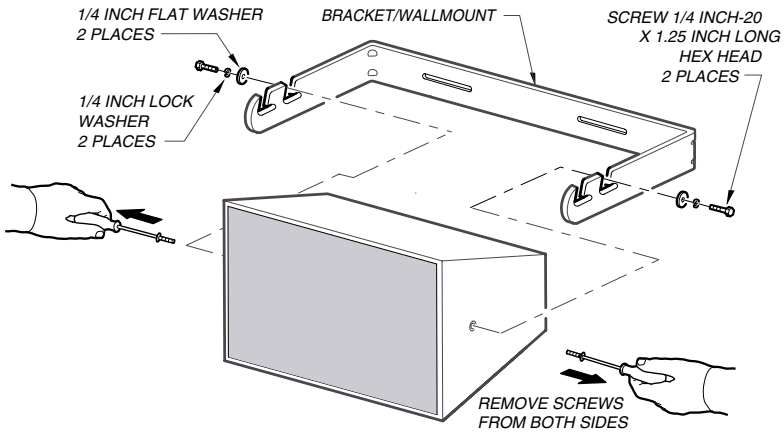

# Bracket Dimensions

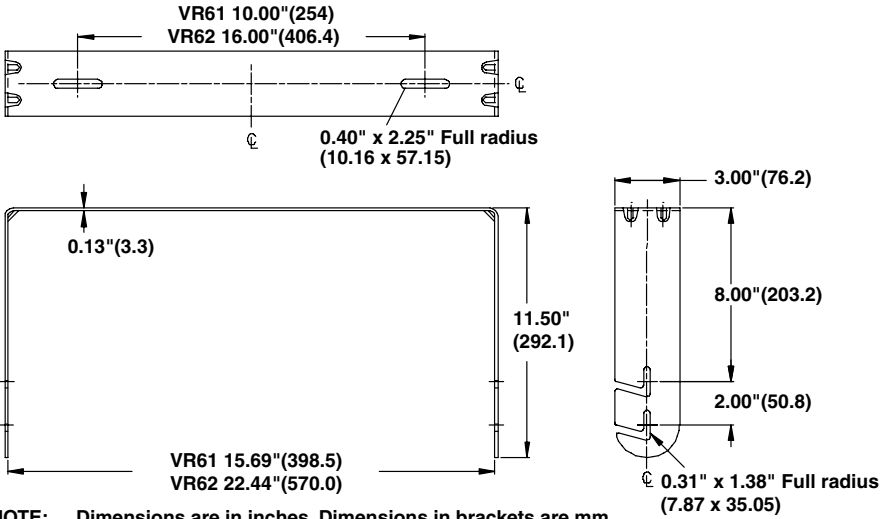

**NOTE:** Dimensions are in inches, Dimensions in brackets are mm  
Tolerance  $\pm 0.03"$ (0.8 mm)

## Horn Rotation Instructions

- The high frequency horn can be rotated through 90 degrees to allow you to choose the best horn pattern for your installation.
- From the factory, the horn is set to give a 90 degrees horizontal horn pattern if the loudspeaker is mounted vertically.
- If you mount the loudspeaker horizontally, you can rotate the horn through 90 degrees to compensate. This is done using a medium phillips screwdriver as follows:
  1. Remove all the screws attaching the grille to the enclosure, and gently remove the grille.
  2. Remove the four screws attaching the horn to the enclosure.
  3. Gently pry the horn assembly away from the enclosure (it may be stuck due to the gasket seal). Support the horn so it does not drop when it comes free.
  4. Rotate the horn through 90 degrees (the horn is marked with 60 and 90 on the edges to show the direction of the pattern). Be careful not to pull on the speaker wires.
  5. Reattach the horn to the enclosure using the four screws.
  6. Replace the grille and secure the screws holding it to the enclosure.

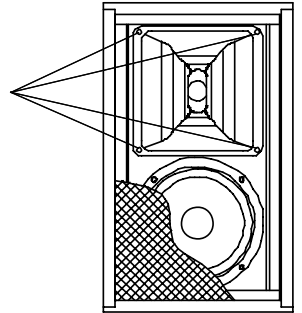

# 4. CONNECTIONS



**WARNING:** To prevent the risk of electric shock, do not connect the loudspeaker with the amplifier switched on. The protective cover over the terminal strip is a safety feature per CE requirements. Replace this cover after making the signal connections.

1. Remove the insulating cover from the loudspeaker input terminal strip.
2. The positive (+) input terminal of the loudspeaker connects to the positive (+) output of your power amplifier.
3. The negative (-) terminal of the loudspeaker connects to the negative (-) output of your power amplifier.
4. Using a small phillips screwdriver, secure the connections.
5. Replace the insulating cover over the loudspeaker input terminal strip.

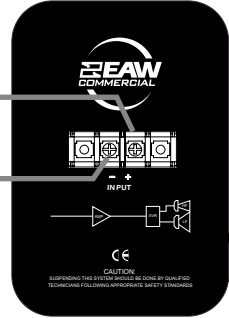

## Loudspeaker Cables

- Use loudspeaker cables with a minimum conductor size for the length you need as listed in these tables. This will minimize power losses to less than 0.5 dB. The cable lengths listed are “up to” lengths. For in-between lengths, use the next larger conductor gauge. Using larger than the recommended conductor size is always permissible. Using smaller than recommended conductor size will result in higher power losses.
- The recommended conductor gauges are listed for AWG (American Wire Gauge) and Metric WG (Metric Wire Gauge). Note that smaller AWG numbers = larger conductors and smaller Metric WG numbers = smaller conductors. The Metric WG is equal to ten times the nominal conductor diameter in millimeters.
- For cable lengths over 200 feet / 60 m at 8 ohms, and over 100 feet / 30 m at 4 ohms, the conductor sizes needed for less than 0.5 dB power losses are rarely practical for physical and cost reasons. As a practical compromise for these situations the recommended conductor gauge is 10 AWG or 25 metric.

Minimum AWG	4 ohm	8 ohm
18	10 ft	25 ft
16	25	50
14	25	75
12	50	125
10	100	200

Min Metric WG	4 ohm	8 ohm
12	3 m	8 m
14	8	15
16	8	25
20	15	40
25	30	60



## Precautions

- To prevent inductive phenomena causing humming or distortion, the speaker cables should not be run together with electrical energy conductors, microphone cables, or line-level audio lines.
- Use speaker cables that have markings to distinguish the polarity, such as insulation or conductors of different colors.
- Before using the loudspeaker, carefully check that all the connections have been made correctly to make sure there are no accidental short circuits that could cause electrical sparks.
- Verify that the polarity of the connections to all of your loudspeakers are correct. When more than one loudspeaker reproduces the same frequencies, but with opposite polarity, there will be sound cancellations. Therefore, if any of the loudspeakers are wired so that the +/- connection polarity is reversed with respect to the others, incorrect reproduction will result. Most notably, the bass response will suffer. This is especially true when loudspeakers are situated in adjacent positions where the sound waves readily interact with each other.

# 5. OPERATION

## Signal Processing

Sometimes external signal processing is desirable to “voice” the loudspeaker to accommodate particular program material, less than optimum acoustics, feedback control, or personal taste. For these purposes, use a suitable electronic signal processor. This can be as simple as a 1/3 octave graphic equalizer or a fully capable DSP (digital signal processor) such as the EAW Commercial DX810, or the EAW MX8750.

## Choosing a Power Amplifier

There is no exact answer to the question of what amplifier size you should use for a loudspeaker. The loudspeaker power rating in EAW Commercial’s specifications only means it has passed a standard power test. This provides a rating that can be used as a point of comparison with other loudspeakers. This rating does not necessarily correspond to the best amplifier size to use nor is it a measure of a “safe” amplifier size to use. Rather, the amplifier should be sized according to both the sound levels required and the type of audio signals that will be reproduced. If you are unsure of how to determine this, consult with a qualified professional or contact EAW Commercial Technical Support.

Preventing damage to the loudspeaker is a function of operating your audio system so that the loudspeaker is not stressed beyond its design limits.

## Operating Tips

- Do NOT drive any of your electronic equipment into clipping, particularly the power amplifiers. This can easily damage the loudspeaker.
- If driven into clipping, even an amplifier with a power output rating lower than the loudspeaker’s power rating can cause damage to a loudspeaker.
- Avoid sustained microphone feedback. This can quickly cause failure of high-frequency drivers.
- Avoid extreme boosts on equalizers as these can cause excessive input to the drivers at the boosted frequencies. Generally, cutting frequencies is preferred to adjust the frequency response.
- With appropriate signal processing, your loudspeaker should produce exceptionally good sound. If it is used in a room with problematic acoustics, there is little you can do to overcome the room problems with electronic adjustments. Your best solution is careful placement and aiming of the loudspeaker so most of the sound is directed only at the audience.
- Most EAW Commercial loudspeakers are capable of sound levels that can be damaging to human hearing. Take precautions so that audiences are not exposed to such levels. If you must expose yourself to these kinds of volume levels, wear adequate hearing protection.
- Take care when moving or lifting the loudspeaker. Injury to you or damage to the loudspeaker can result from careless handling.

# 6. SPECIFICATIONS

Model	VR61	VR62
<b>Woofers</b>	6" x 1	6" x 2
<b>Woofers Loading</b>	Baffle, sealed	Baffle, sealed
<b>Tweeter</b>	1" exit Compression	1" exit Compression
<b>Tweeter Loading</b>	60 x 90 Horn	60 x 90 Horn
<b>Operating Range (-10 dB)</b>	85 Hz - 20 kHz	80 Hz - 20 kHz
<b>Horizontal Beamwidth - Nominal (rotatable)</b>	90 degrees	90 degrees
<b>Vertical Beamwidth - Nominal (rotatable)</b>	60 degrees	60 degrees
<b>Axial Sensitivity (whole space SPL)</b>	90 dB 85 Hz to 20 kHz	92 dB 80 Hz to 20 kHz
<b>Peak Sensitivity (whole space SPL)</b>	93 dB 20 Hz to 20 kHz	96 dB 20 Hz to 20 kHz
<b>Input Impedance - Nominal</b>	8 ohm	8 ohm
<b>Input Impedance - Minimum</b>	3.6 ohm @ 2660 Hz	7.1 ohm @ 225 Hz
<b>Recommended High Pass Filter</b>	≥ 75 Hz, 24 dB/octave Butterworth	≥ 70 Hz, 24 dB/octave Butterworth
<b>Power Handling</b>	150 W 35 V @ 8 ohms	250 W 45 V @ 8 ohms
<b>Calculated Maximum SPL Average</b>	112 dB	116 dB
<b>Calculated Maximum SPL Peak</b>	118 dB	122 dB
<b>Mounting Supplied</b>	Bracket	Bracket
<b>Height</b>	15.50 in / 393.7 mm	22.25 in / 565.1 mm
<b>Width</b>	9.50 in / 241.3 mm	9.50 in / 241.3 mm
<b>Depth</b>	10.65 in / 270.4 mm	10.65 in / 270.4 mm
<b>Dimension Tolerance</b>	± 0.1 in / 2.5 mm	± 0.1 in / 2.5 mm
<b>Weight</b>	16 lb / 7.3 kg	25 lb / 11.3 kg

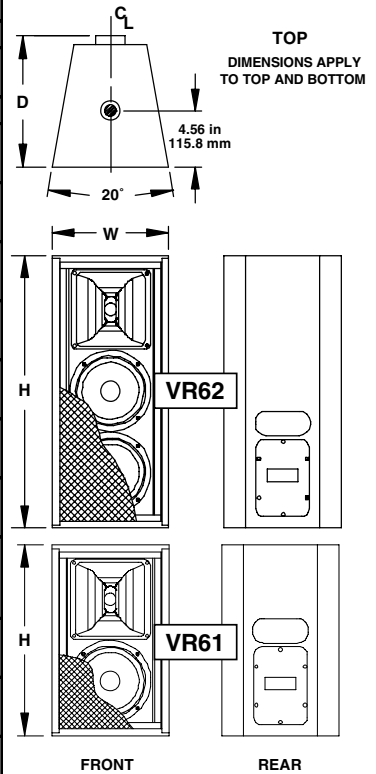

## Disclaimer

EAW Commercial continually engages in research related to product improvement, new materials, and production methods. Design refinements are introduced into existing products without notice as a routine expression of that philosophy. For this reason, any current EAW Commercial product may differ in some respect from its published description, but will always equal or exceed the original design specifications unless otherwise stated.

“EAW Commercial” is a trademark of LOUD Technologies Inc.

All other brand names mentioned are trademarks or registered trademarks of their respective holders, and are hereby acknowledged.



# PERFORMANCE GRAPHS

## VR61 Impedance vs Frequency

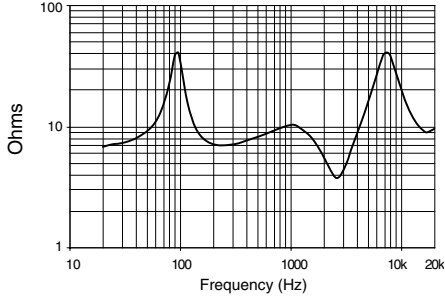

## VR62 Impedance vs Frequency

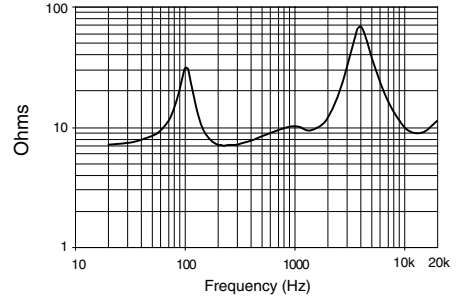

## VR61 Axial Response vs Frequency

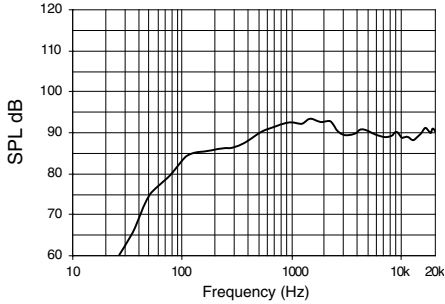

## VR62 Axial Response vs Frequency

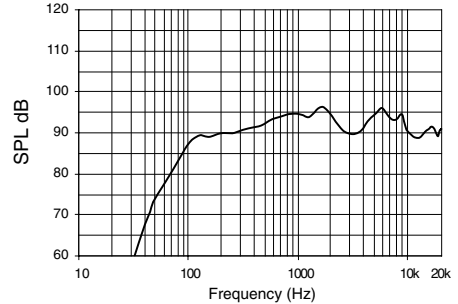

## VR61 Beamwidth vs Frequency

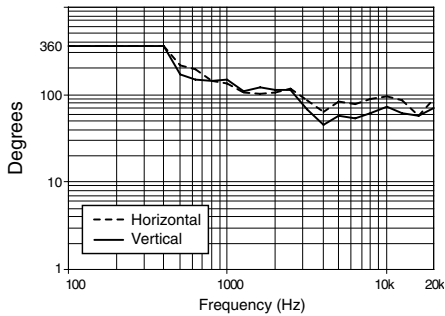

## VR62 Beamwidth vs Frequency

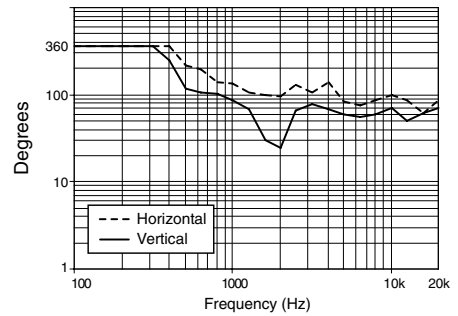

# 7. TROUBLESHOOTING

Loudspeaker difficulties usually fall into one of the following categories. The causes for each are listed in the most likely order of probability.

## No Sound or Low Output

- Loudspeaker cables or connectors are not wired correctly or are faulty. Check all cabling, referring to these instructions for the correct connections. The best way to check a suspect cable is to swap it with a known good cable. Check the loudspeaker's input panel to verify correct cable connections.
- Electronic equipment is not turned on, or the level controls are not adjusted properly. Make sure that all equipment in the signal path is powered up, and that all controls are set to appropriate levels for normal operation.
- Loudspeaker is not working. Connect the loudspeaker cable to a known good loudspeaker, leaving all equipment set to the same levels. If the problem disappears, the loudspeaker is probably not working. Contact EAW Commercial Technical Support for appropriate troubleshooting.

## Distorted Sound

- The power amplifier is clipping. The signal level is exceeding the limits of your system and you must reduce the level.
- Other electronic equipment is being over-driven. Ensure that no equipment in the signal chain is being overdriven. For example: input(s) or summing bus in the mixing console, equalizers, etc.
- Driver(s) not working properly. Contact EAW Commercial Technical Support for appropriate troubleshooting.

## Partial Sound (frequency band missing)

- Incorrect EQ settings in the electronic equipment. Ensure that all EQ settings and filters on the mixing console, preamplifier, or other equipment are set for normal operation. Ensure that level controls on electronic crossovers and associated amplifiers are correctly set, and that all cables and connections for such equipment are connected and working properly.
- Driver not working properly. Contact EAW Commercial Technical Support for appropriate troubleshooting.
- The crossover network inside the loudspeaker is not working properly. Contact EAW Commercial Technical Support for appropriate troubleshooting.

# 8. SERVICE and MAINTENANCE

## Maintenance

Usually, your EAW Commercial loudspeaker will not require regular maintenance for normal use. However, you can do several things to keep your loudspeaker in good operating and cosmetic condition.

- **Testing:** Periodically test your loudspeaker for proper performance. A simple test is to play a CD through it using well-defined, articulate, wide-range program material. Listen to ensure all drivers are working properly and for any evidence of distortion or other extraneous sounds. Test at several volume levels: very low, normal, and high.
- **Mounting/Rigging:** Any mounting or rigging hardware should be regularly inspected for security, wear, deformation, corrosion, and any other circumstances that may affect the load-handling capability. Immediately remove from service and replace any hardware whose load-handling capability may be compromised.
- **Cleaning:** Cleaning the exterior of the enclosure will depend on the type of “dirt.” Dust, food spills, or similar contaminants can usually be removed with a cloth dampened with water, or a mild household cleaner. Avoid using any strong solvents as this may damage the finish. Turn the amplifiers off before cleaning.
- **Scratches or Dents in Wood Enclosures:** Minor scratches on the enclosure can be painted over with an outdoor latex paint, or simply a colored in with a “Sharpie” or artist’s marking pen. More serious gouges or dents should be sanded out, filled with wood putty, and repainted. Touch-up paint in pints and quarts is available through EAW Commercial Technical Support.

## Service

If your loudspeaker should require servicing, please follow these instructions:

1. Call EAW Commercial Tech Support at 1-888-337-7404, 7 am to 5 pm PST (Monday-Friday), to verify the problem and obtain a Service Request Number. Be sure to have the serial number of the unit when you call. You must have a Service Request Number in order to obtain warranty service at the factory or at an authorized service center. You can also email EAW Commercial Tech Support at: [support@eawcommercial.com](mailto:support@eawcommercial.com)
2. Pack the unit in its original packaging. **THIS IS VERY IMPORTANT.** LOUD Technologies is not responsible for any damage that occurs during shipping due to non-conventional packaging. Original packaging helps to minimize the possibility of shipping damage.
3. Include a legible note stating your name, (no P.O. boxes), daytime phone number, Service Request Number, and a detailed description of the problem, including how we can duplicate it.
4. Write the Service Request Number in **BIG BOLD PRINT** on top of the box.

5. Tech Support will tell you where to ship the unit when you call for a Service Request Number. We suggest insurance for all forms of cartage.

## **EAW Commercial Technical Support**

Phone (USA/Canada)	888-337-7404
Phone	425-892-6503
Fax	425-485-1152
Address	One Main Street Whitinsville, MA 01588
Web site	<a href="http://www.eawcommercial.com">www.eawcommercial.com</a>
e-mail	<a href="mailto:support@eawcommercial.com">support@eawcommercial.com</a>

## **9. WARRANTY**

**Warranty:** LOUD Technologies Inc. requires its authorized EAW Commercial distributors abide by the following warranty terms for all EAW Commercial brand products (all dates are from the date of delivery from an Authorized EAW Commercial Distributor to the end user/installation site):

Speakers – 5 years; Active Electronics – 5 years; Accessories – 2 years.

**What Is Covered:** Defects in workmanship and materials and against malfunctions. EAW Commercial distributors must remedy all such defects and malfunctions without charge for parts or labor if the warranty applies. Final determination of warranty coverage lies solely with each authorized EAW Commercial distributor.

**What Is Not Covered:** This warranty does not extend to damage or malfunctions resulting from, but not limited to, shipment, improper installation, misuse, neglect, abuse, normal wear, accident, or to any product on which the serial number has been modified or removed. Exterior defects in or damage to the exterior appearance are specifically excluded from this warranty. EAW Commercial distributors shall not be liable for incidental or consequential damages resulting from the use of EAW Commercial products. Repairs and/or modifications by other than an Authorized EAW Commercial Distributor automatically voids this warranty.





EAW Commercial | One Main Street | Whitinsville, MA 01588 USA

TEL toll free within US/Canada 888.337.7404 | TEL outside US 425.892.6503 | FAX 425.485.1152

[www.eawcommercial.com](http://www.eawcommercial.com)

© 2004 LOUD Technologies Inc. All Rights Reserved. EAW Commercial is a registered trademark of LOUD Technologies Inc.